



DELHI PUBLIC SCHOOL GWALIOR

UNDER THE AEGIS OF
THE DELHI PUBLIC SCHOOL SOCIETY, NEW DELHI



Holiday Assignment

Class - XII

Session (2026-27)



Dear Parents

Greetings of the day!

Vacations are the best time to relax and enjoy. Summer vacations are the reason behind fun in the sun, beach and shadow of the umbrella, but it is also the time to keep some analogy of academics alive in the fun to chisel the inherent potential inside your child. My suggestion to you is to spend these holidays being sociable and be vibrant in undertaking your plans so that the vacation is made purposeful.

To begin with, enhance every precious moment prudently by motivating your child to read informative and enlightening books. Help them improve their speech by conversing with them on every possible occasion and strop their vocabulary by providing them with new words. Spend substantial time visiting your kith and kin and people in your vicinity. Hold parley with your child on daily happenings and crucial world events as this is the best time to update, put forth your thoughts, notions and ideas before your ward and ask for an opinion, be a constant supporter of tolerance and disseminate it amongst people, teach your child to help and let him/her realize the meaning of real happiness and harmony and certainly root out all possible ill feelings and factions. Try being friendly and benevolent to all, let your child play the part in family reunions which will strengthen your family bond. Look out for the ways to abrade the plodding routine and take up some supportive vigorous activities with your child like swimming, cycling, jogging, painting or any other activity that your child enjoys.

It's your time to make every single moment eventful and memorable for your child and fill them with loads of experiences, which he/she eagerly wants to share with his/her pals and Educators when returned to School.

I wish you a pleasant vacation!

Regards

**Principal
Delhi Public School Gwalior**

ADD ONS TO MAKE YOUR VACATION MEANINGFUL !!

Childhood is a crucial stage of development. Most of life's important lessons are learnt here! Let us join hands and make sincere efforts to augment and hone the learning process of the child through inculcation of self learning and keen observation.

- * Let us attempt to enable them by allowing them to assume responsibilities of the routine household and shopping chores. (e.g.: laying the table, serving the guests, making their beds, buying groceries from the nearby stores etc.)
- * Let us make them aware about their social responsibilities which will transform them into a responsible citizen of our society. (e.g.: keeping the surroundings clean, make use of public litter bins, switching off lights / fans / closing the taps properly etc.)
- * They should be taught how to connect with Almighty God through prayers and meditation. (e.g.: daily prayers, thought of the day, meditate to improve the concentration etc.)
- * Socialize and connect with people, neighbours and relatives. (e.g.: meeting & greeting neighbours, helping the elderly around, be friendly to the peers etc.)

We wish all the great for your summer holiday time. May all the pleasure in the world embrace you, let your fun endless with friends and family.

Note :Kindly do all the Holiday Assignments neatly and submit it latest by July 10,2026.

SUBJECT – ENGLISH (CORE)

Holiday Homework Guidelines

Students are required to complete the following work neatly and systematically in an A4 size file:

1. Presentation of Work

- * Use A4 size ruled sheets for all written work.
- * Maintain a neat and legible handwriting.
- * Leave proper margins on both sides.
- * Each answer should begin on a fresh page.

2. Content Requirements

- * Attempt both questions carefully.
- * Answers must be well-structured, relevant, and within the word limit (where specified).
- * Use appropriate introduction, body, and conclusion format.

3. Handwritten Work

- * All Questions – Question 1 (Intertextual Question), Question 2 (Article Writing) and Question 3 (Article Writing) must be handwritten.

4. Printed Pages

The following pages should be typed and printed:

- * Cover Page / Certificate
- * Index
- * Acknowledgement

5. File Arrangement (in order)

1. Cover Page
2. Certificate
3. Acknowledgement
4. Index
5. Answer to Question 1
6. Answer to Question 2
7. Answer to Question 3

6. Creativity & Effort

- * You may add a simple border or relevant illustrations to enhance presentation.
- * Ensure the work reflects original thinking and understanding.

7. Submission - 10 July 2026

- * Submit the file within the given deadline.
- * Late submissions may affect assessment.

Q1. In "The Last Lesson" Franz feels deep regret for not paying attention in class, similar to the speaker's realisation in "My Mother At Sixty Six". Discuss how both texts explore the theme of appreciating what we have, before it's too late. (250 words)

Q2. Write an article on "War is never justified in the modern world". (250 words)

Q3. Is nationalism a cause of conflict or a source of unity? (250 words)

-----X-----

SUBJECT – MATHEMATICS

General Instructions :

- Holiday Assignment consists of Multiple Choice questions, Case based questions and solve the following questions.
- All the work to be done in A4 sized ruled sheets which are to be arranged in a stick file.
- All the best! Stay Home, Stay Safe!

Multiple Choice Questions

- Q.1 If the matrix $A = \begin{bmatrix} 0 & a & 3 \\ 2 & b & -1 \\ c & 1 & 0 \end{bmatrix}$ is a skew-symmetric matrix, then $a+b+c =$
- (a) -5 (b) 0 (c) 5 (d) None of these
- Q.2 The value of $\begin{vmatrix} 5^2 & 5^3 & 5^4 \\ 5^3 & 5^4 & 5^5 \\ 5^4 & 5^5 & 5^6 \end{vmatrix}$ is
- (a) 5^2 (b) 0 (c) 5^{13} (d) 5^9
- Q.3 If $A = \begin{bmatrix} x & 0 \\ 1 & 1 \end{bmatrix}$ and $B = \begin{bmatrix} 4 & 0 \\ -1 & 1 \end{bmatrix}$, then the value of x which $A^2 = B$ is
- (a) -2 (b) 2 (c) 2 or -2 (d) 4
- Q.4 If $x = -4$ is a root of $\begin{vmatrix} x & 2 & 3 \\ 1 & x & 1 \\ 3 & 2 & x \end{vmatrix} = 0$, then the sum of the other two roots is
- (a) 4 (b) -3 (c) 2 (d) 5
- Q.5 If A and B are two matrices such that $AB = B$ and $BA = A$, then $A^2 + B^2$ is equal to
- (a) 2AB (b) 2BA (c) A + B (d) AB
- Q.6 The number of all possible matrices of order 3x3 with each entry 0 or 1 or -1 is
- (a) 27 (b) 3^6 (c) 81 (d) 3^9
- Q.7 If B is non-singular matrix and A is a square matrix, then $\det(B^{-1} A B)$ is equal to
- (a) $\det(A^{-1})$ (b) $\det(B^{-1})$ (c) $\det(A)$ (d) $\det(B)$
- Q.8 If $A = \begin{bmatrix} 1 & 0 & 1 \\ 0 & 0 & 1 \\ a & b & 2 \end{bmatrix}$, then $aI + bA + 2A^2$ equals
- (a) A (b) -A (c) abA (d) None of these
- Q.9 For two matrices A and B given that $A^{-1} = \frac{1}{4} B$ then the inverse of 4A is
- (a) 4B (b) B (c) $\frac{1}{4} B$ (d) $\frac{1}{16} B$

Assertion and Reason Based Questions

In the following questions, a statement of Assertion (A) is followed by a statement of Reason (R). Choose the correct answer out of the following choices.

- (a) Both A and R are true and R is the correct explanation of A.
- (b) Both A and R true but R is not the correct explanation of A.
- (c) A is true but R is false.
- (d) A is false but R is true.

Q.10 **Assertion (A)** : If $f(x) = x^2 + x + 1$ and $g(x) = x^2 - 1$ then $\frac{f(x)}{g(x)}$ may be discontinuous at some points.

Reason (R) : If $f(x)$ and $g(x)$ are continuous functions on common domain D, then $\frac{f(x)}{g(x)}$ is continuous on D.

Q.11 Let $f(x) = x|x|$ and $g(x) = \sin x$

Assertion (A) : $g \circ f$ is differentiable at $x = 0$ and its derivative is continuous at that point.

Reason (R) : $g \circ f$ is twice differentiable at $x = 0$.

Q.12 **Assertion (A)** : If the area of a circle increases at a uniform rate, then its perimeter varies inversely as the radius.

Reason (R) : The ratio of change of area of a circle with respect to its perimeter is equal to the radius.

Case Study Based Questions

Q.13 Over speeding increases fuel consumption and decreases fuel economy as a result of tyre rolling friction and air resistance. While vehicles reach optimal fuel economy at different speeds fuel.

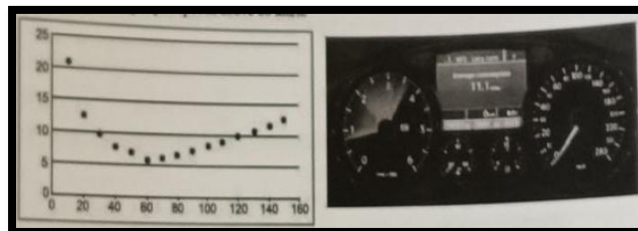

The relation between fuel consumption F (l/100 km) and speed V (km/h) under some constraints is given as $F = \frac{V^2}{500} - \frac{V}{4} + 14$

On the basis of the above information, answer the following questions:

- (i) Find F , when $V = 40$ km/h.
- (ii) Find $\frac{dF}{dV}$
- (iii) (a) Find the speed V for which fuel consumption F is minimum.

OR

- (b) Find the quantity of fuel required to travel 600 km at the speed V at which $\frac{dF}{dV} = -0.01$

Q.14 On her birthday Ira decided to donate some money to children of an orphanage home. If there were 8 children less, everyone would have got ₹10 more. However, if there were 16 children more, everyone would have got ₹10 less. Let the number of children be x and the amount donated by Ira to each child be y .

Based on the information given above, answer the following questions:

- (i) Form the system of linear equations describe the above information and representation in the matrix form.
- (ii) The number of children who were given some money by Ira.

(iii) How much amount is given to each child by Ira?

OR

How much amount Ira spends in distributing the money to all the students of the orphanage?

Q.15 The traffic police has installed Over Speed Violation Detection (OSVD) system at various locations in a city. These cameras can capture a speeding vehicle from a distance of 300 m and even function in the dark.

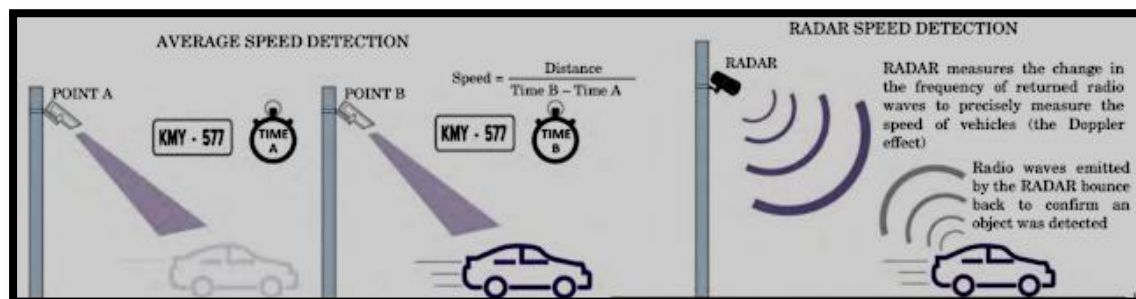

A camera is installed on a pole at the height of 5 m. It detects a car travelling away from the pole at the speed of 20 m/s. At any point, x m away from the base of the pole, the angle of elevation of the speed camera from the car C is θ .

On the basis of the above information, answer the following questions:

- Express θ in terms of height of the camera installed on the pole and x .
- Find $\frac{d\theta}{dx}$
- Find the rate of change of angle of elevation with respect to time at an instant when the car is 50 m away from the pole.

OR

If the rate of change of angle of elevation with respect to time of another car at a distance of 50 m from the base of the pole is $\frac{3}{101}$ radian/sec, then find the speed of the car.

Short Answer Type Questions

Q.16 If $A_\alpha = \begin{bmatrix} \cos \alpha & \sin \alpha \\ -\sin \alpha & \cos \alpha \end{bmatrix}$, then show that $A_\alpha A_\beta = A_{\alpha+\beta}$

Q.17 In the interval of $\frac{\pi}{2} < x < \pi$, find the value of x for which the matrix $\begin{bmatrix} 2 \sin x & 3 \\ 1 & 2 \sin x \end{bmatrix}$ is singular.

Q.18 If the matrix $A = \begin{bmatrix} 0 & a & 3 \\ 2 & b & -1 \\ c & 1 & 0 \end{bmatrix}$ is skew-symmetric, find the value of a, b and c .

Q.19 Prove that the determinant $\begin{vmatrix} x & \sin \theta & \cos \theta \\ -\sin \theta & -x & 1 \\ \cos \theta & 1 & x \end{vmatrix}$ is independent of θ .

Q.20 If $A = \begin{bmatrix} 1 & 3 & 3 \\ 1 & 4 & 3 \\ 1 & 3 & 4 \end{bmatrix}$, then verify that $A \text{ adj } A = |A|I$. Also find A^{-1} .

Q.21 Prove that the inverse of an invertible matrix symmetric matrix is a symmetric matrix.

Q.22 Find the value of the constant λ so that the function given below is continuous at $x=-1$.

$$f(x) = \begin{cases} \frac{x^2-2x-3}{x+1}, & x \neq -1 \\ \lambda, & x = -1 \end{cases}$$

Q.23 If $f(x) = \begin{cases} x^2, & \text{if } x \geq 1 \\ x & \text{if } x < 1 \end{cases}$, then show that f is not differentiable at $x=1$.

Q.24 If $y = \operatorname{cosec}(\cot^{-1} x)$, then prove that $\sqrt{1+x^2} \frac{dy}{dx} - x = 0$

Q.25 Differentiate $\tan^{-1}\left(\frac{\cos x}{1-\sin x}\right)$ w.r.t x $-\frac{\pi}{2} < x < \frac{\pi}{2}$

Q.26 Differentiate $(\log x)^{\sin x}$ w.r.t x

Q.27 If $y = \sqrt{\sin x + \sqrt{\sin x + \sqrt{\sin x + \dots \dots \infty}}}$ then prove that $\frac{dy}{dx} = \frac{\cos x}{2y-1}$

Q.28 If $u = \sin(m\cos^{-1} x)$, $v = \cos(m\sin^{-1} x)$. Prove that $\frac{du}{dv} = \frac{\sqrt{1-u^2}}{\sqrt{1-v^2}}$

Q.29 Differentiate $\log(1+x^2)$ w.r.t to $\tan^{-1} x$.

Q.30 Differentiate $\tan^{-1}\left(\frac{\sqrt{x-x}}{1+x^{3/2}}\right)$ w.r.t. x .

Q.31 Water is dripping out from a conical funnel at a uniform rate of $4 \text{ cm}^3/\text{sec}$. through a tiny hole at the vertex in the bottom. When the slant height of the water is 3 cm , find the rate of decrease of the slant height of the water-cone. Given that the vertical angle of the funnel is 120° .

Q.32 Find the interval in which the function $f(x) = \tan^{-1}(\sin x + \cos x)$ is increasing in $(0, \pi)$.

Q.33 If $y^x + x^y + x^x = a^b$ find $\frac{dy}{dx}$.

Long Answer Type Questions

Q.34 If $x = a(\cos \theta + \log \tan \frac{\theta}{2})$ and $y = a \sin \theta$ find the value of $\frac{d^2y}{dx^2}$ at $\theta = \frac{\pi}{4}$.

Q.35 AB is a diameter of a circle and C is any point on the circle. Show that the area of ΔABC is maximum when it is isosceles.

Q.36 For the matrix $A = \begin{bmatrix} 3 & 1 \\ 7 & 5 \end{bmatrix}$, find x and y , so that $A^2 + xI = yA$.

Q.37 If $(x-a)^2 + (y-b)^2 = c^2$. Prove that $\frac{\left\{1 + \left(\frac{dy}{dx}\right)^2\right\}^{3/2}}{\frac{d^2y}{dx^2}}$ is a constant independent of a and b .

Q.38 Find $\frac{dy}{dx}$, when $\sin(xy) + \frac{x}{y} = x^2 - y$.

Q.39 If $ax^2 + 2hxy + by^2 + 2gx + 2fy + c = 0$, then show that $\frac{dy}{dx} \cdot \frac{dx}{dy} = 1$.

Q.40 A metal box with a square base and vertical sides is to contain 1024 cm^3 of water the material for the top and bottom costs ₹5/cm² and the material for the sides costs ₹2.50/cm². Find the least cost of the box

-----X-----

SUBJECT – APPLIED MATHEMATICS

- The following guidelines are issued by CBSE to schools for the session 2026-27.
- Project work and record : 5 marks and year end presentation/ viva : 5 marks

Following are the topics for the projects to be done individually. One has to select any one topic and prepare a detailed report on it

- 1) Predicting the Outcome of an Election- Exit Polls.
- 2) Weather Prediction (To study how weather is predicted and understand the use of mathematics in weather prediction).
- 3) Risk Assessments by Insurance Firms from Data.
- 4) Stock Price Movements.
- 5) To show application of mathematics in real life in maximizing the profit of Kirana stores.
- 6) Effect of Temperature and Rain Variations on Various Crops.
- 7) To analyze what the infant mortality rate of a country is and how we can predict it.
- 8) Predicting a Stock Market Crash.

- **Steps involved in the conduct of the project:**

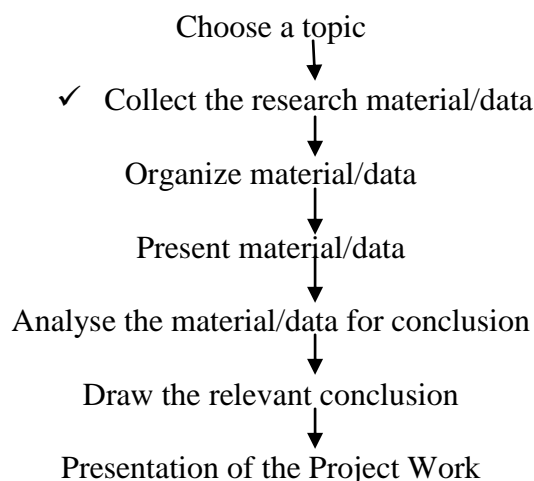

- **Expected Checklist for the project work:**

- ✓ Introduction of topic/title
- ✓ Identifying the causes, events, consequences and/or remedies
- ✓ Various stakeholders and effect on each of them.
- ✓ Advantages and disadvantages of situations or issues identified.
- ✓ Short term and long term implications of strategies suggested in the course of research.

- ✓ Validity, reliability, appropriateness and relevance of data used for research work and for presentation in the project file.
 - ✓ Presentation and writing that is succinct and coherent in project file.
 - ✓ Citation of the material referred to, in the file in footnotes, resources section, bibliography etc.
- The project report should include
Title page, Acknowledgements, Certificate, Contents page(Index), Introduction, Body of report, Evaluation, Conclusions and Future Work, Bibliography and Appendix.

-----X-----

SUBJECT – PHYSICS

General instructions:

1. Do all the questions in a folder or available notebook.
2. Write answers in a proper sequence.
3. Do neat & clean work.
4. Draw diagrams where ever required.

Objective Questions

- Q1. Two charges q and $4q$ are separated by distance r . The point where net electric field is zero lies:
- | | |
|-----------------------------------|------------------------------------|
| A. Between charges, closer to q | B. Between charges, closer to $4q$ |
| C. Outside near q | D. Outside near $4q$ |
- Q2. Electric field due to an infinite plane sheet is:
- | | |
|------------------------|-------------|
| A. Depends on distance | B. Constant |
| C. Zero | D. Infinite |
- Q3. Potential inside a uniformly charged spherical shell is:
- | | | | |
|---------|-------------|-------------|--------------------|
| A. Zero | B. Constant | C. Infinite | D. Varies linearly |
|---------|-------------|-------------|--------------------|
- Q4. Energy stored in capacitor is proportional to:
- | | | | |
|--------|----------|----------|--------|
| A. V | B. V^2 | C. $1/V$ | D. Q |
|--------|----------|----------|--------|
- Q5. If dielectric constant increases, capacitance:
- | | | | |
|--------------|--------------|-----------------|-----------------|
| A. Decreases | B. Increases | C. Remains same | D. Becomes zero |
|--------------|--------------|-----------------|-----------------|
- Q6. Drift velocity is inversely proportional to:
- | | | | |
|-------------------|--------------------|----------------|-----------|
| A. Electric field | B. Relaxation time | C. Temperature | D. Charge |
|-------------------|--------------------|----------------|-----------|
- Q7. Kirchoff's junction rule is based on:
- | | |
|------------------------|------------------------|
| A. Energy conservation | B. Charge conservation |
| C. Ohm's law | D. Power law |
- Q8. In Wheatstone bridge, condition for balance is:
- | | | | |
|--------------|--------------|----------------------------|---------|
| A. $P+Q=R+S$ | B. $P/Q=R/S$ | C. $P \times Q=R \times S$ | D. None |
|--------------|--------------|----------------------------|---------|
- Q9. Electric field intensity is maximum at:
- | | |
|---------------------|-------------------------|
| A. Centre of sphere | B. Surface of conductor |
| C. Infinity | D. Inside dielectric |

- Q10. Work done moving charge in equipotential surface is:
 A. Maximum B. Minimum C. Zero D. Infinite
- Q11. Internal resistance depends on:
 A. Material and dimensions B. Voltage
 C. Current D. Power
- Q12. Potential due to dipole varies as:
 A. $1/r$ B. $1/r^2$ C. $1/r^3$ D. r^2
- Q13. Current density J is given by:
 A. I/A B. V/R C. IR D. ρA
- Q14. Resistivity unit is:
 A. Ω B. Ωm C. Ω/m D. m/Ω
- Q15. Capacitors in parallel have:
 A. Same charge B. Same voltage C. Same energy D. Same current

Assertion Reasoning Questions

Direction of questions : In the following questions, A statement of Assertion (A) is followed by a statement of Reason (R).

- (A) Both (A) and (R) are true and (R) is the correct explanation of (A).
 (B) Both (A) and (R) true but (R) is NOT the correct explanation of (A).
 (C) (A) is correct but (R) is not correct
 (D) (A) is not correct but (R) is correct.

Q16. **Assertion:** Electric field inside conductor is zero.

Reason: Charges rearrange to cancel field.

Q17. **Assertion:** Potential is constant inside conductor.

Reason: No electric field inside.

Q18. **Assertion:** Capacitance increases with dielectric.

Reason: Dielectric reduces electric field.

Q19. **Assertion:** Current same in series.

Reason: Charge conserved.

Q20. **Assertion:** Resistivity increases with temperature.

Reason: Electron collisions increase.

Descriptive Questions

Q21. When electric dipole is placed in uniform electric field, its two charges experience equal and opposite forces, which cancel each other and hence net force on electric dipole in uniform electric field is zero. However these forces are not collinear, so they give rise to some torque on the dipole. Since net force on electric dipole in uniform electric field is zero, so no work is done in moving the electric dipole in uniform electric field. However some work is done in rotating the dipole against the torque acting on it.

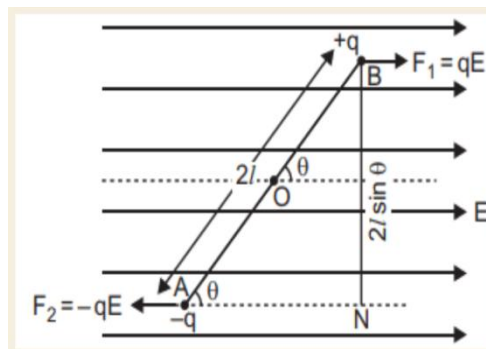

1. The dipole moment of a dipole in a uniform external fields E is P . Then the torque τ acting on the dipole is

A) $\tau = P \times E$	B) $\tau = P \cdot E$
C) $\tau = 2(P + E)$	D) $\tau = (P + E)$

2. An electric dipole consists of two opposite charges, each of magnitude $1\mu\text{C}$ separated by a distance of 2 cm. The dipole is placed in an external field of 10^5 N/C . The maximum torque on the dipole is

A) $0.2 \times 10^{-3} \text{ Nm}$	B) $1 \times 10^{-3} \text{ Nm}$
C) $2 \times 10^{-3} \text{ Nm}$	D) $4 \times 10^{-3} \text{ Nm}$

3. Torque on a dipole in electric field is minimum when angle is equal to

A) 0°	B) 90°
C) 180°	D) Both (a) and (c)

4. When an electric dipole is held at an angle in a uniform electric field, the net force F and torque τ on the dipole are

A) $F = 0, \tau = 0$	B) $F \neq 0, \tau \neq 0$
C) $F = 0, \tau \neq 0$	D) $F \neq 0, \tau = 0$

5. An electric dipole of moment p is placed in an electric field of intensity E . The dipole acquires a position such that axis of the dipole makes an angle with the direction of the field. Assuming that potential energy of the dipole to be zero when $\theta = 90^\circ$, the torque and the potential energy of the dipole will respectively be

A) $PE \sin \theta, -PE \cos \theta$	B) $PE \sin \theta, -2PE \cos \theta$
C) $PE \sin \theta, 2PE \cos \theta$	D) $PE \cos \theta, -PE \sin \theta$

Q22. Derive an expression for the electric potential at any point along the axial line of an electric dipole.

- Q23. (i) Derive an expression for drift velocity of free electron in a conductor in terms of relaxation time of electrons.
 (ii) Establish a relation between electric current and drift velocity.

Q24. An electric dipole of length 4cm when placed with its axis making an angle of 60° with a uniform electric field, experience a torque of $4\sqrt{3} \text{ N-m}$. Calculate the potential energy of the dipole if it has charge $\pm 8\text{nC}$.

Q25. A uniformly charged conducting sphere of 2.4 m diameter has a surface charge density of $80\mu\text{Cm}^{-2}$.

- (i) Find the charge on the sphere
- (ii) What is the total electric flux leaving the surface of the sphere?

Q26. The sum of two point charges is $7\mu\text{C}$. they repel each other with a force of 1N when kept 30cm apart in free space. Calculate the value of each charge.

Q27. The equivalent capacitance of the combination between point A and B in the given figure is $4\mu\text{F}$.

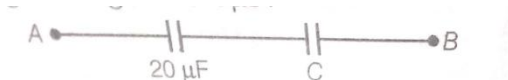

- (i) Calculate the capacitance of the capacitor C.
- (ii) Calculate the charge on each capacitor if a 12V battery is connected across terminal A and B.
- (iii) What will be the potential drop across each capacitor?

Q28. Calculate the current drawn from the battery in the given network

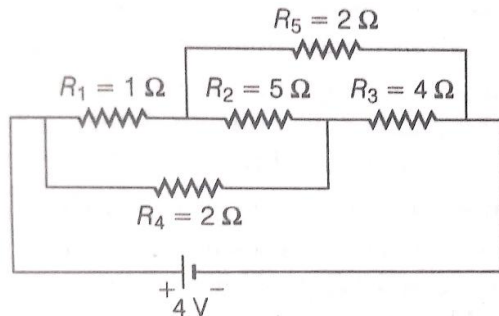

- Q29. (i) Derive an expression for the capacitance of a parallel plate capacitor with air present between the two plates.
- (ii) In the network, four capacitors C_1 , C_2 , C_3 and C_4 connected as shown in figure.

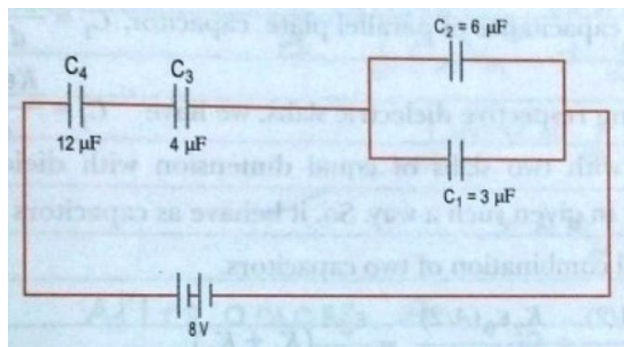

- (a) Calculate the net capacitance in the circuit.
 - (b) If the charge on the capacitor C_1 is $6 \mu\text{C}$, (i) calculate the charge on the capacitors C_3 and C_4 and (ii) net energy in the capacitors C_3 and C_4 connected in series.
- Q30. Two cells of emf E_1 , E_2 and internal resistances r_1 and r_2 respectively are connected in parallel as shown in figure.

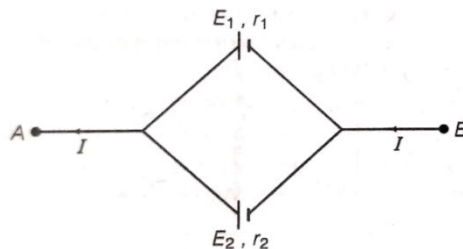

Deduce the expression for

- (i) The equivalent emf of the combination.
- (ii) The equivalent resistance of the combination
- (iii) The potential difference between the points A and B.

-----X-----

SUBJECT – CHEMISTRY

HOLIDAY HOMEWORK ALCOHOL PHENOL AND ETHERS

Objective questions

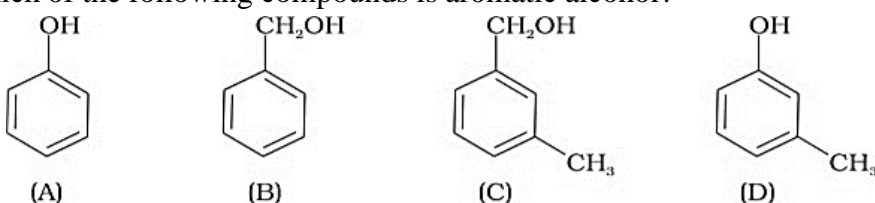
1. Monochlorination of toluene in sunlight followed by hydrolysis with aq. NaOH yields.
(i) o-Cresol (ii) m-Cresol
(iii) 2, 4-Dihydroxytoluene (iv) Benzyl alcohol
2. How many alcohols with molecular formula $C_4H_{10}O$ are chiral?
(i) 1 (ii) 2 (iii) 3 (iv) 4
3. What is the correct order of reactivity of alcohols in the following reaction?
 $R-OH + HCl \xrightarrow{(ZnCl_2)} R-Cl + H_2O$
(i) $1^\circ > 2^\circ > 3^\circ$ (ii) $1^\circ < 2^\circ > 3^\circ$
(iii) $3^\circ > 2^\circ > 1^\circ$ (iv) $3^\circ > 1^\circ > 2^\circ$
4. CH_3CH_2OH can be converted into CH_3CHO by _____.
(i) catalytic hydrogenation (ii) treat with $LiAlH_4$
(iii) treat with pcc (iv) treatment with $KMnO_4$
5. The process of converting alkyl halides into alcohols involves _____.
(i) addition reaction (ii) substitution reaction
(iii) dehydrohalogenation reaction (iv) rearrangement reaction
6. Which of the following compounds is aromatic alcohol?

(i) A, B, C, D (ii) A, D (iii) B, C (iv) A
7. Give IUPAC name of the compound given below.
$$\begin{array}{ccccccc} CH_3 & - & CH & - & CH_2 & - & CH_2 & - & CH & - & CH_3 \\ & & | & & & & & & | & & \\ & & Cl & & & & & & OH & & \end{array}$$

(i) 2-Chloro-5-hydroxyhexane (ii) 2-Hydroxy-5-chlorohexane
(iii) 5-Chlorohexan-2-ol (iv) 2-Chlorohexan-5-ol
8. IUPAC name of m-cresol is _____.
(i) 3-methylphenol (ii) 3-chlorophenol
(iii) 3-methoxyphenol (iv) benzene-1,3-diol

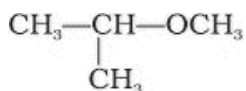
9. IUPAC name of the compound is _____.



- (i) 1-methoxy-1-methylethane (ii) 2-methoxy-2-methylethane
(iii) 2-methoxypropane (iv) isopropylmethyl ether

10. Which of the following compounds will react with sodium hydroxide solution in water?

- (i) $\text{C}_6\text{H}_5\text{OH}$ (ii) $\text{C}_6\text{H}_5\text{CH}_2\text{OH}$
(iii) $(\text{CH}_3)_3\text{C-OH}$ (iv) $\text{C}_2\text{H}_5\text{OH}$

11. Which of the following species can act as the strongest base?

- (i) $\ominus\text{OH}$ (ii) $\ominus\text{OR}$
(iii) $\ominus\text{O C}_6\text{H}_5$ (iv) 

12. Phenol is less acidic than _____.

- (i) Ethanol (ii) o-nitrophenol
(iii) o-methyl phenol (iv) o-methoxy phenol

13. Which of the following is most acidic?

- (i) Benzyl alcohol (ii) Cyclohexanol
(iii) Phenol (iv) m-Chlorophenol

14. Mark the correct order of decreasing acid strength of the following compounds.

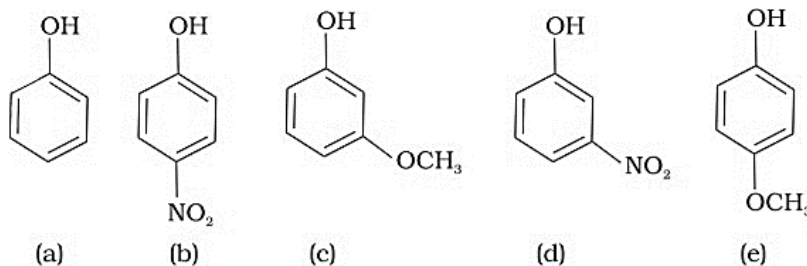

- (i) $e > d > b > a > c$ (ii) $b > d > a > c > e$
(iii) $d > e > c > b > a$ (iv) $e > d > c > b > a$

15. Mark the correct increasing order of reactivity of the following compounds with HBr/HCl .

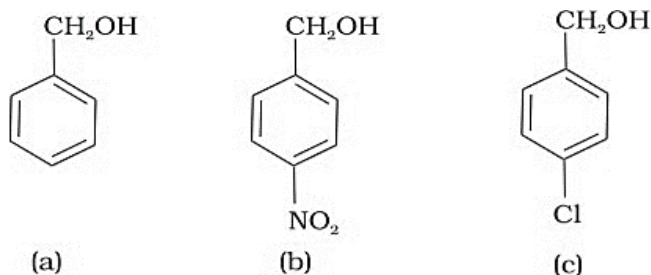

- (i) $a < b < c$ (ii) $b < a < c$
(iii) $b < c < a$ (iv) $c < b < a$

Assertion Reasoning Questions

choose any one of the following four responses.

- (a) Assertion and Reason both are correct and the Reason is a correct explanation of the Assertion.
- (b) Assertion and Reason both are correct but Reason is not a correct explanation of the Assertion.
- (c) Assertion is correct but reason is wrong statement.
- (d) Assertion is wrong but reason is correct statement.

16. **Assertion :** The bond angle in ether is less than tetrahedral angle.

Reason : There is strong repulsive interaction between the two bulky (–R) groups in ether.

17. **Assertion :** Phenols are more reactive towards electrophilic substitution reaction compared to benzene.

Reason : OH group in phenol increases the electron density in ortho and para position due to +M effect.

18. **Assertion :** Only warm water is required in the formation of picric acid from 2,4,6-trinitrochlorobenzene.

Reason : Presence of three electron withdrawing groups make it unstable.

19. **Assertion :** Arylhalides are not used in the preparation of ethers by Williamson's synthesis

Reason : Aryl halides undergo elimination reaction in presence of alkoxide.

20. **Assertion :** In Phenol, bromination can take place even in absence of Lewis acid.

Reason ; Monobromination occurs in presence of CHCl_3 or CS_2 at low temperature

Short questions

21. What is the correct formula for ethylene glycol alcohol? Mention its uses.

22. Why are ethers more volatile than alcohol?

23. Explain Williamson ether synthesis.

24. Name the chemical test commonly used to distinguish between the following pairs of compounds.

- i) n-Propylalcohol and isopropyl alcohol.
- ii) Methanol and ethanol
- iii) Cyclohexanol and phenol
- iv) Phenol and anisole

25. Identify the compounds.

- (i) An alcohol A, in reaction with acidified potassium dichromate, produces B.
- (ii) When the alcohol is dehydrated with concentrated H_2SO_4 , it produces C.
- (iii) Compound D is produced in the reaction of C and aqueous solution of H_2SO_4 . D is an isomer of A.
- (iv) D is an oxidation resistant compound while A gets oxidized easily.

26. An organic compound A turns the colour of aqueous solution of FeCl_3 violet. When A is treated with NaOH in presence of CO_2 under pressure at 400 K temperature, it produces compound B which is a non-steroidal anti-inflammatory drug. If acidified, B produces C

which in reaction with acetyl chloride gives compound D which is prescribed by doctors to alleviate pain. Can you recognize the compounds?

27. a) How do you convert ethanol to propan-2-ol.
 b) Write the mechanism of the following reaction:

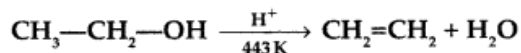

- c) Write the IUPAC name of the following compound:

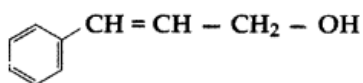

- d) Why phenol undergoes electrophilic substitution more easily than benzene?

CASE STUDY BASED QUESTIONS

28. Phenols are much more acidic than alcohols, and as a result they dissolved in basic solutions. A typical alcohol has a pK_a of 16–17. In contrast, phenol is 10 million times more acidic: its pK_a is 10.

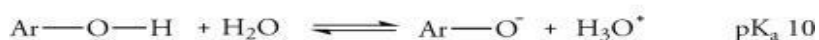

However, phenols are not sufficiently acidic to react with aqueous sodium bicarbonate. Phenols are more acidic when the ring is substituted with electron-withdrawing groups.

Q.(i) Which has highest value of ionization constant K_a ?

- a) ethanol b) propan-1 ol c) Phenol d) 4-methyl phenol

Q.(ii) Both phenol and carboxylic acids are acidic in nature. Which of the following is/are used to distinguish them?

- a) NaOH b) NaHCO_3 c) neutral FeCl_3 d) both b and c

Q.(iii) Explain why Phenols are more acidic than alcohols? Write one reaction to support your answer.

OR

Out of Phenol, 3,5dinitrophenol and 2,4,6-trinitrophenol ,which is most acidic and why?

LONG ANSWER TYPE QUESTIONS:

29. An alcohol A ($\text{C}_4\text{H}_{10}\text{O}$) on oxidation with acidified potassium dichromate gives acid B ($\text{C}_4\text{H}_8\text{O}_2$). Compound A when dehydrated with conc. H_2SO_4 at 443 K gives compound C. Treatment of C with aqueous H_2SO_4 gives compound D ($\text{C}_4\text{H}_{10}\text{O}$) which is an isomer of A. Compound D is resistant to oxidation but compound A can be easily oxidised. Identify A, B, C and D and write their structures.

30. a) Account for the following:
 i) o-nitrophenol is more steam volatile than p-nitrophenol.
 ii) t-butyl chloride on heating with sodium methoxide gives 2- methyl propene instead of t-butyl methyl ether.
- b) Write the reactions involved in the following:
 i) Reimer-Tiemann reaction
 ii) Friedal-Crafts alkylation of phenol.
- c) Give simple chemical test to distinguish between ethanol and phenol.

-----x-----

SUBJECT – BIOLOGY

General instructions:

1. Do all the questions in a folder or available notebook.
2. Write answers in a proper sequence.
3. Do neat & clean work.
4. Draw diagrams where ever required.

MULTIPLE CHOICE QUESTIONS:

1. What would happen if corpus luteum is not degenerated ?
 - (a) Progesterone will not be secreted
 - (b) Endometrium will disintegrate
 - (c) Proliferation of endometrium will take place
 - (d) Ovulation will take place
2. Klinefelter syndrome has the genetic make up
 - (a) 44 autosomes + xxy
 - (b) 44 autosomes + xo
 - (c) 45 autosomes + xx
 - (d) 45 autosomes + xy
3. "Cleistogamous flowers are invariably autogamous because"
 - (a) These flowers do not open at all.
 - (b) There is no chance of cross – pollen landing on the stigma
 - (c) These flowers have exposed anthers and stigma.
 - (d) These flowers are wind pollinated
4. Which of the following statements is correct
 - (a) Surgical methods of contraception does not prevent gamete formation
 - (b) In E.T techniques, embryos are always transferred into the uterus
 - (c) Oral pills are very popular contraceptives among the rural women
 - (d) All STDs are not completely curable
5. The human blood groups are determined by
 - (a) 4 alleles in which IA is dominant.
 - (b) 3 alleles in which IA and IB are codominant.
 - (c) 3 alleles in which none is dominant.
 - (d) 3 alleles in which IA and i are codominant.
6. Which of the following does not follow Mendel's law of dominance?
 - (a) Pisum sativum
 - (b) Mirabilis jalapa
 - (c) Lathyrus odoratus
 - (d) None of these
7. To analyse the genotype of an organism, it is made to
 - (a) Self cross
 - (b) Cross with recessive parent
 - (c) Cross with dominant parent
 - (d) Cross with another species.
8. A disease caused by an autosomal primary non-disjunction is
 - (a) Down's syndrome
 - (b) Klinefelter's syndrome
 - (c) Turner's syndrome
 - (d) Sickle cell anemia
9. Thalassaemia and sickle cell anemia are caused due to a problem in globin molecule synthesis. Select the correct statement
 - (a) Both are due to a qualitative defect in globin chain synthesis
 - (b) Both are due to a quantitative defect in globin chain synthesis

- (c) Thalassemia is due to less synthesis of globin molecules
 (d) Sickle cell anemia is due to a quantitative problem of globin molecules
10. Which one from those given below is the period for Mendel's hybridization experiments?
 (a) 1856 – 1863 (b) 1840 – 1850 (c) 1857 – 1869 (d) 1857 -1870
11. The transfer of pollen from anther to stigma is called:
 (a) Fertilization (b) Pollination (c) Germination (d) Dissemination
12. Double fertilization is characteristic of:
 (a) Gymnosperms (b) Angiosperms (c) Bryophytes (d) Pteridophytes
13. The embryo sac is located in:
 (a) Anther (b) Ovary (c) Ovule (d) Stigma
14. Which cell forms the endosperm?
 (a) Egg cell (b) Synergids (c) Central cell (d) Antipodals
15. The functional unit of testis is:
 (a) Nephron (b) Seminiferous tubule
 (c) Alveoli (d) Follicle

Assertion & Reason Question:

The following questions consist of two statements – Assertion (A) and Reason (R). Answer these questions selecting the appropriate option given below:

- (a) Both A and R are true, and R is correct explanation of the assertion.
 (b) Both A and R are true, but R is not the correct explanation of the assertion.
 (c) A is true, but R is false.
 (d) A is false, but R is true.

16. **Assertion:** Pollen grains can remain viable for months in some species.

Reason: Pollen viability depends on temperature and humidity.

17. **Assertion:** Spermatogenesis begins at puberty.

Reason: Testosterone secretion increases at puberty.

18. **Assertion:** STDs can be prevented by using condoms.

Reason: Condoms act as a physical barrier.

19. **Assertion:** Linked genes do not assort independently.

Reason: They are located on the same chromosome.

20. **Assertion:** IUDs increase phagocytosis of sperms.

Reason: They enhance fertilization chances.

Case based question:

21. Double fertilization and triple fusion are two important features observed in angiosperm plants. Flowers are the reproductive structures containing male and female reproductive structures

called stamens and pistils respectively. Pollen grains are produced by the anthers of the stamens. After pollination, the pollen enters the embryo sac and performs the process of fertilization.

- (a) What do you mean by double fertilization?
- (b) Where does triple fusion take place in a flowering plant?

OR

- (b) Why is it so called?
- (c) Mention one significance of each of double fertilization and triple fusion.

- 22. Why is the process of fertilisation in a flowering plant referred to as double fertilisation?
- 23. State one advantage and one disadvantage of cleistogamy.
- 24. Write the function of each of the following:
 - (a) middle piece of human sperm
 - (b) luteinizing hormone in human males
- 25. What is corpus luteum? Under what conditions does it undergo degeneration?
- 26. Differentiate between morula and blastula stages of mammalian embryo.
- 27. Describe the contraceptive actions of IUDS.
- 28. Expand the following: (i) ZIFT (ii) ICSI (iii) GIFT (iv) IUT
- 29. (a) mention any four strategies adopted by flowering plants to prevent self-pollination.
(b) define the term emasculation.
- 30. Draw neat and well labelled diagram of anatropous ovule showing mature embryo-sac.

-----X-----

SUBJECT – ACCOUNTANCY

A) MULTIPLE CHOICE QUESTIONS

- 1. Ram and Mohan were partners in a firm sharing profit and losses in the ratio of 3:2. Their capitals were ₹2,40,000 and ₹4,80,000 respectively. They were entitled to interest on capital @ 10%. The firm earned profit of ₹36,000 during the year. The interest on Ram's capital will be
 - a) ₹24,000
 - b) ₹21,600
 - c) ₹14,400
 - d) ₹12,000
- 2. A manager gets 5% commission on net profit after charging such commission. Gross profit ₹2,90,000 and expenses of indirect nature other than manager's commission are ₹80,000. Commission amount will be:
 - a) ₹10,500
 - b) ₹10,000
 - c) ₹7,500
 - d) ₹11,000
- 3. A and B are partners. They draw for personal use ₹24,000 and ₹16,000 respectively. Interest is chargeable @ 6% p.a. on drawings. What is the interest on drawings?
 - a) A ₹720 and B ₹480
 - b) A ₹1,440 and B ₹960
 - c) A ₹120 and B ₹80
 - d) None of these

4. A, B and C are partners sharing profits in the ratio of 5:4:1. C is given guarantee that his share in a year will not be less than ₹50,000. Profit for the year ended 31st March, 2021 is ₹4,00,000. Deficiency in the guaranteed profit of C is to be borne by B. Deficiency to be borne by B is:
 a) Deficiency of C ₹15,000 met by B b) Deficiency of C ₹10,000 met by B
 c) Deficiency of C ₹40,000 met by B d) None of these
5. A, B and C are partners in a firm without a partnership deed. C demands interest on loan of ₹60,000 advanced by him at the market rate of 12%. The amount of interest received by him will be:
 a) ₹7,200 b) Nil c) ₹5,400 d) ₹3,600
6. If equal amount is withdrawn in the beginning of each month for personal use, period for which interest will be charged will be:
 a) 7 months b) 6 months c) 5 months d) 6.5 months
7. Following factors affect the goodwill except
 a) Nature of business b) The form of business entity
 c) Technical Know-how d) Efficiency of Management
8. The term 'Number of Years' Purchase' means
 a) The number of years during which the purchaser of goodwill expects that the profit due to goodwill are likely to arise in future.
 b) Number of years in which goodwill is purchased.
 c) Number of years for which goodwill purchased will not help the firm in earning similar profits.
 d) None of the above
9. Capital employed by a partnership firm is ₹25,00,000. Its average profit is ₹3,00,000. The normal rate of return in similar type of business is 10%. The amount of super profit is;
 a) ₹2,50,000 b) ₹50,000
 c) ₹30,000 d) ₹2,80,000
10. A firm earns profit of ₹60,000. Normal rate of return being 10%. Assets of the firm are ₹7,20,000 and liabilities are ₹2,40,000. Find the value of goodwill by capitalization of average profit method.
 a) ₹2,40,000 b) ₹1,80,000
 c) ₹1,20,000 d) ₹60,000

B) ASSERTION AND REASON BASED QUESTIONS

Read the following statements: Assertion (A) and Reason (R). Choose one of the correct alternative.

- a) both (A) & (R) both are true and (R) is correct explanation of (A)
 b) both (A) & (R) both are true and (R) is not correct explanation of (A)
 c) (A) is true but (R) is false
 d) (A) is false but (R) is true
- 1) **Assertion :** Interest on Loan to partner is charged @ 6% p.a., if partnership deed does not provide for charging of interest.

Reason : In the absence of partnership deed, provisions of the Partnership Act, 1932 apply. Thus, Interest on Loan to partner should be charged @ 6% p.a. otherwise interest is allowed at the agreed rate of interest.

- 2) **Assertion:** Value of goodwill calculated on Average Profit Method or Super Profit Method is same.

Reason : Value of goodwill on Average profit method and super profit method cannot be same as the basis of valuation is different.

C) NUMERICALS

1. The partners of a firm Jay, Veeru and Gabbar distributed the profits for the year ended 31st March, 2022, ₹6,40,000 in the ratio of 3:3:2, without providing for the following adjustments:
- Jay and Gabbar were entitled to a salary of ₹12,000 each p.a.
 - Veeru was entitled for a commission of ₹32,000.
 - Veeru and Gabbar had guaranteed a minimum profit of ₹2,80,000 p.a. to Jay and any deficiency to be borne equally by Veeru and Gabbar.

Pass the necessary journal entry for the above adjustment in the books of the firm.

2. A, B and C are in partnership, profits being shared in the ratio of 3:2:1. subject to the following:
- C's share of profit guaranteed to be not less than ₹2,40,000 p.a.
 - B gives a guarantee to the effect that gross fee earned by him for the firm shall be equal to his average gross fee for the preceding five years when he was carrying on profession alone, which on an average works out at ₹4,00,000.
The profit for the first year of the partnership are ₹12,00,000. The gross fee earned by B for the firm is ₹2,56,000. You are required to show Profit and Loss Appropriation Account after giving effect to the above.
3. On 1st April, 2018, a firm had assets of ₹5,00,000 excluding stock of ₹1,00,000. Partners' Capital Account showed a balance of ₹3,00,000. The current liabilities were ₹50,000 and the balance constituted the reserve. If the normal rate of return is 8%, the Goodwill of the firm is valued at ₹3,00,000 at four year of purchase of super profit, find average profit of the firm.
4. The average profit earned by a firm is ₹4,50,000 which includes undervaluation of stock of ₹30,000 on an average basis. The capital invested in the business is ₹42,00,000 and the normal rate of return is 7%. Calculate goodwill of the firm on the basis of 5 times the super profit.

-----X-----

SUBJECT – ECONOMICS

A) MULTIPLE CHOICE QUESTIONS

1. Which of the following agency is responsible of issuing ₹1 currency note in India?
- | | |
|--------------------------|-------------------------|
| a) Reserve Bank of India | b) Ministry of Commerce |
| c) Ministry of Finance | d) Niti Aayog |

2. In India, coins of ₹10 are issued by:

a) State Bank of India	b) Reserve Bank of India
c) Ministry of Finance	c) Department of Revenue

3. Demand Deposits include:
 - a) saving account deposits and fixed deposits
 - b) saving account deposits and current account deposits
 - c) current account deposits and fixed deposits..

4. A thing which is commonly accepted as medium of exchange is called:

a) Commodity	b) money
c) material	d) item

5. Money serves as a common denomination. The function of money highlighted is:

a) Store of value	b) Standard of deferred payments
c) Unit of account	d) Medium of exchange

6. Credit creation in commercial banks is determined by

a) Cash Reserve ratio	b) Statutory liquidity Ratio
c) Initial Deposits	d) All the above

7. Which of the following is not a quantitative Method of credit control?

a) Open Market Operation	b) Margin Requirements
c) Variable reserve Ratio	d) Bank Rate Ratio

8. The percentage of demand deposits which the commercial banks are legally required to maintain as their liquid assets is called:

a) Statutory liquidity Ratio	b) Deposit ratio
c) Cash Reserve ratio	d) Legal reserve ratio

9. Which of the following is not the function of Central bank?

a) Bank facilities to government	b) Lending to commercial bank
c) Bank facilities to Public	d) Lending to Public

10. Reverse repo rate:

a) Generates interest income	b) is increased to control inflation
c) is not a policy rate	d) Both (a) and (b)

B) ASSERTION AND REASON BASED QUESTIONS

Read the following statements: Assertion (A) and Reason (R). Choose one of the correct alternative.

- a) both (A) & (R) both are true and (R) is correct explanation of (A)
- b) both (A) & (R) both are true and (R) is not correct explanation of (A)
- c) (A) is true but (R) is false
- d) (A) is false but (R) is true

1. **Assertion (A)**- Central bank holds the foreign exchange reserves to influence exchange rate.

Reason (R)- selling and purchasing of foreign exchange influences the exchange rate.

2. **Assertion (A)**- Credit creation process increases the money supply in economy .

Reason (R)- through the credit creation process commercial banks can distribute loans many times as compare to their primary deposits.

C) UNDERSTANDING BASED QUESTIONS

1. Classify the following as final good or intermediate good:
 - a) Soft drinks purchased by a school canteen
 - b) Coal purchased by a factory
 - c) Seeds purchased by a farmer
 - d) Sewing machine purchased by a homemaker
 - e) Books purchased by a bookseller
 - f) Paper purchased by a publisher
 - g) Exhaust fans used for making water coolers
 - h) Furniture purchased by a school

2. Classify the following as stock or flow variables:
 - a) Sale of rice as on January 1, 2025
 - b) Population of a country at a point of time
 - c) Capital
 - d) Interest on capital
 - e) Income
 - f) Bank deposits
 - g) Supply of money in a country
 - h) Wealth
 - i) Capital formation
 - j) Water in a overhead tank

D) CASE STUDY BASE QUESTIONS

Read the following case study paragraph carefully and answer the questions on the basis of the same.

India's total Money Supply (M3) stood at Rs 18907383 crore as on April 9th 2020, recording a rise of 11.3% over the same time last year. Currency with the public stood at Rs 2787941 crore, up 16.7% over the year. Demand deposits with banks were up 17% at Rs 1867606 crore. Time deposits with banks were also up 9.6% at Rs 14205545 crore. The bank credit to commercial sector edged up 5.1% on year to Rs 11552069 crores. However, this indicates moderation from 7.2% at the same time last year.

1. How does increase in deposits with commercial banks will affect credit creation process :-
 - a) Credit creation process will increase
 - b) Credit creation process will remain unaffected
 - c) Credit creation process will reduce
 - d) None of above

2. M3 is consist of:-
 - a) C +OD + Time deposits 12 KVS RO RAIPUR
 - b) C + DD + OD + time deposits
 - c) M1 + deposits of post office saving bank
 - d) All of above

3. What is indicated by increasing deposits:-
 - a) People prefer to save more now

- b) Income level of people are increasing
- c) People prefer to keep money in the bank accounts after demonetization
- d) All of above

PROJECT:

Role of RBI in Control of Credit (350- 400 words)

-----X-----

SUBJECT – BUSINESS STUDIES

ANSWER THE FOLLOWING CASE STUDIES:

Q.1 Neeraj is selected for the post of software developer in an IT Company. On the first day of his joining Mehul, his project manager tells Neeraj the during the course of his work he will come across many such opportunities which may tempt him to misuse his powers for individual or family's benefit at the cost of larger general interest of the company. In such situations, he should rather exhibit exemplary behavior as it will raise his stature in the eyes of the company. Also, for interacting with anyone in the company on official matters, he should adopt the formal chain of authority and communication.

In context of the above case:

- (a) Identify and explain the various principles of management that Mehul is advising Neeraj to follow while doing his job.
- (b) List any two values that Mehul wants to communicate to Neeraj.

Q.2 Harshita has successfully emerged as the owner of the best modular kitchen manufacturer firm in Delhi. Her friend Vartika is highly inspired by Harshita's success in business. In order to understand the essence of successful business management Vartika decides to spend a week in her office. Vartika observes that a deliberated effort is made to integrate the diverse activities of the organisation. Like whenever the sales manager makes a plan to raise the sales target, he also consults other department managers i.e the production manager, the purchase manager, the finance manager, etc. in order to avoid any problem that may raise in future. Moreover, work among the people working in the production department in divided in such a manner that where the work of one person ends, the work of the next person begins. Therefore, everybody makes efforts to complete his/her work on time, and the workers do not create obstruction in each other's work.

In contest of the above case:

- (a) Identify the concept being described in the above paragraph.
- (b) How does the concept as identified in part (a) of the question help in carrying out management functions successfully?

Q.3 Hema is one of the most successful managers of her company. 'Kobe Ltd'. She uses her creativity and initiative in handling challenging situations at work. The knowledge gained by her during her student days at a renowned management institute as well as through her observation and experience over the years is applied by Hema in a skillful manner in the context of the realities of a given situation. She often reads books and other literature in various fields of management to keep her knowledge updated.

- (i) An aspect of the nature of management is being highlighted in the above description. Identify the aspect.
- (ii) Explain any three features of the aspect identified in part (i)

Q.4 Production manager of Beta Ltd. took special care of the interest and ability of his subordinates while distributing work among them. He was of the firm opinion that a worker should be given one work again and again so that he may become expert in it. One day he took round of his department and noticed that the workers were not doing their job quickly. On enquiry, he learnt that the workers worked non-stop which is main cause of their slow speed. He immediately issued an order that during their working hours, the workers will have an interval to take rest.

- (a) State the principle of management followed here. Explain.
- (b) Which technique of scientific management is indicated in above para?

Q.5 Karan Nath took over 'D' north Motor Company' from his ailing father three months ago. In the past the company was not performing well. Karan was determined to improve the company's performance. He observed that the methods of production as well as selection of employees in the company were not scientific. He believed that there was only one best method to maximise efficiency. He also felt that once the method is developed, the workers of the company should be trained to learn that 'best method'. He asked the production manager to develop the best method and carry out the necessary training. The production manager developed this method using several parameters right from deciding the sequence of operations, place for men, machines and raw materials till the delivery of the product to the customers. This method was implemented throughout the organisation. It helped in increasing the output, improving the quality and reducing the cost and wastage.

Identify the principles of scientific management being discussed above:

Answer the following questions in detail:

- Q1. Define Management and Discuss its features.
- Q2. "Successful organization do not achieve their goal by chance but by following a deliberate process". Identify and explain its importance.
- Q3. Explain Coordination and discuss its features.
- Q4. Discuss the features and importance of Principles of management.
- Q5. Explain Henry Fayol's principles of management stating the positive and negative aspects of each principle.
- Q6. Explain Scientific management and discuss its techniques.

-----X-----

SUBJECT – HISTORY

A FEW SUGGESTIVE TOPICS FOR PROJECTS

1. The Indus Valley Civilization-Archaeological Excavations and New Perspectives
2. The History and Legacy of Mauryan Empire
3. "Mahabharat"- The Great Epic of India
4. The History and Culture of the Vedic period
5. Buddha Charita
6. A Comprehensive History of Jainism
7. Bhakti Movement- Multiple Interpretations and Commentaries.
8. The Mystical Dimensions of Sufism
9. Global Legacy of Gandhian Ideas
10. The Architectural Culture of the Vijayanagar Empire

11. Life of Women in the Mughal Rural Society
12. Comparative Analysis of the Land Revenue Systems Introduced by the Britishers in India
13. The Revolt of 1857- Causes; Planning & Coordination; Leadership, Vision of Unity
14. The Philosophy of Guru Nanak Dev
15. The Vision of Kabir
16. An Insight into the Indian Constitution
17. Comparative Study of Stupas and Pillar Edicts
18. Comparative Study of Mughal and Vijayanagar Architecture

Projects are an imperative component in enhancing students learning with the related themes. In the research project, students can go beyond the textbook and explore the world of knowledge. They can conceptualise under the embedded themes.

Note-

1. **Steps involved in the conduct of the project: Students may work upon the following lines as suggested:**
 1. Choose a Title/Topic
 2. Need of the Study, Objective of the Study
 3. Hypothesis
 4. Content -Timeline, Maps, Mind maps, Pictures, etc. (Organization of Material/Data Present Material/Data)
 5. Analysing the Material/Data for Conclusion
 6. Draw the Relevant Conclusion
 7. Bibliography
2. **Expected Checklist for the Project Work:**
 1. Introduction of topic/ title
 2. Identifying the causes, events, consequences and/or remedies
 3. Various stakeholders and effect on each of them
 4. Advantages and disadvantages of situations or issues identified
 5. Short-term and long-term implications of strategies suggested during research
 6. Validity, reliability, appropriateness, and relevance of data used for research work and for presentation in the project file
 7. Presentation and writing that is succinct and coherent in project file
 8. Citation of the materials referred to, in the file in footnotes, resources section, bibliography etc.

Project Work has broadly the following phases: Synopsis/ Initiation, Data Collection, Data Analysis and Interpretation, Conclusion.

-----x-----

SUBJECT – GEOGRAPHY

1. WRITING SKILLS

- ❖ Prepare notes -
 - Book-1- Fundamentals of Human Geography
 - * Chapter -1 -Human Geography, Nature and Scope
 - * Chapter 2 - World population, Distribution, Density, and Growth
 - * Chapter 3- Human Development
 - * Chapter 4- Primary Activities

Book-2 India People and Economy

* Chapter 1- Population - Density, Distribution, Growth and Density

* Chapter 2- Human Settlement

- ❖ NCERT Textbook Exercises -Complete exercises and questions from the NCERT textbook related to the chapter.

2. MAP SKILLS

- ❖ Mark the following on the political outline map of World and paste it in your notebook.

- * Areas of subsistence gathering (Fig 4.2)
- * Major areas of nomadic herding of the world (Fig 4.4)
- * Major areas of commercial livestock rearing (Fig 4.6)
- * Major areas of extensive commercial grain farming (Fig 4.12)
- * Major areas of mixed farming of the World (Fig 4.14)

3. PRACTICAL FILE

Complete the following chapters in the practical file -

- Chapter 1 - Data- It's Sources and Complications
- Chapter 2 - Data Processing
- Chapter 3 - Graphical Representation of Data
- Chapter 4- Spatial Information Technology

-----X-----

SUBJECT – POLITICAL SCIENCE

- According to CBSE academic guidelines and standard practices, your file should follow this sequence:
- **Cover Page:** Project title, student name, roll number, and school details.
- **Certificate:** Signed by the teacher/supervisor confirming the work is original.
- **Acknowledgement:** Expressing gratitude to those who assisted (teachers, parents, etc.).
- **Index:** Table of contents with page numbers.
- **Introduction:** Background and scope of your chosen topic.
- **Main Content:** The detailed research, divided into headings/sub-headings (25–30 pages suggested).
- **Conclusion:** Your findings, reflections, and learnings.
- **Bibliography:** A list of books, websites, and sources used.

Suggestive Topics (ANY ONE)

1. NAM- 1961 to present times.
2. Division of Germany with special focus on the construction and dismantling of the Berlin Wall.
3. CIS-Central Asian Republics
4. Disintegration of USSR with special focus on Gorbachev.
5. Arab Spring
6. Cover the negative as well as positive aspects of relationship between India and the following countries.
7. ASEAN
8. European Union and India
9. BRICS
10. SAARC
11. India's Nuclear Policy
12. United Nations with focus on India's candidature in Security Council.
13. UN Agencies – UNICEF, UNESCO, WHO

14. Pandemics: Covid 19- Its global impact (focus on worldwide cooperation and preparedness along with controversies (please collect newspaper clippings for the same)
15. Partition of India-Theory behind it and its legacy
16. Comparison between NITI AAYOG and Planning Commission and their contribution in India's Development.
17. Election Commission of India and Electoral Roll and its revision
18. Elections 2019- Rise of BJP and Downfall of Congress (1989-2019).
19. Imposition of Emergency in India
20. NDA III and NDA IV – Social and Economic welfare programmes.

Submission Guidelines

- **Mode:** The project must be handwritten on A4-size sheets.
- **Word Limit:** Usually between 1500–2000 words.
- **Visual Aids:** Enhance your project with relevant maps, cartoons, photographs, and newspaper clippings.

-----X-----

SUBJECT – PSYCHOLOGY

Q.1 Read and write about famous historical figure's Psychological condition.

- a) Abraham Lincoln
- b) Julius Caesar
- c) Alexander the great
- d) Henry VI of England
- e) Isaac Newton

❖ **Note – Kindly do in practical file.**

Q.2 Watch any 2 movies related to Psychological disorder.

- ❖ TaareZammen Per (Disleksiya)
- ❖ Dear Zindgi (Depression)
- ❖ Rain Man (Autism)

Q.3 What is case study?

Prepare a practical file of case study on given topics. (Choose any one topic).

- ❖ Anxiety Disorder.
- ❖ Effect of parental conflicts on children.
- ❖ Obsession and compulsive disorder.
- ❖ Alcohol dependence.

-----X-----

SUBJECT – SOCIOLOGY

Prepare the given sociology project as per the CBSE guidelines. Prepare a rough draught on any one of the following topics the Rough draught should have complete and detailed information along with the critical analysis of the topics.

Some suggested topics for project work are:

1. Mode of Public Transpiration (Local Railway or Bus Station)
2. Domestic application (use of cooking fuel/mode, fan, cooler, etc.)
3. Use of public spaces (roadside, empty land, etc.)
4. Changing aspirations of school children at different ages (e.g. classes 5, 8, 11)
5. Place of the means of communication in social life (from mobile phones to satellite TV)

6. Child labour/women empowerment
7. Social Mobility and its modern development
8. Dowry System
9. Role of social media
10. Globalisation
11. Child marriage
12. Politics and Multi Dimensional poverty
13. Caste system
14. Social Inequality
15. Caste Movement in India

Students should prepare the Sociology project under the following headings

1. Acknowledgement
2. Index
3. Cover page
4. Project synopsis
5. Data/Statistical analysis
6. Analysis/Explanation and Interpretation
7. Conclusion
8. Bibliography

-----X-----

SUBJECT – ENTREPRENEURSHIP

Choose the correct option:

1. An entrepreneur is a person who:

a) Works for others	b) Starts a business and takes risk
c) Invests money only	d) Manages government firms

2. Which of the following is NOT a characteristic of an entrepreneur?

a) Risk-taking	b) Innovation
c) Fear of failure	d) Decision-making ability

3. Idea fields refer to:

a) Sources of business finance	b) Areas where business ideas can be generated
c) Government policies	d) Marketing strategies

4. SWOT analysis includes:

a) Sales, Work, Operations, Time	b) Strengths, Weaknesses, Opportunities, Threats
c) Strategy, Work, Order, Trade	d) System, Work, Output, Target

5. Entrepreneurial idea should be:

a) Unrealistic	b) Profitable and feasible
c) Based on luck	d) Only theoretical

6. Which of the following is a source of business ideas?

a) Market trends	b) Customer complaints
c) Technology	d) All of these

7. Feasibility study includes:

a) Technical feasibility	b) Financial feasibility
c) Market feasibility	d) All of these

8. A business plan is:
 a) A marketing tool
 b) A written document describing business goals
 c) A financial statement
 d) A legal document
9. The first step in writing a business plan is:
 a) Marketing plan
 b) Executive summary
 c) Financial plan
 d) Production plan
10. Business plan is useful for:
 a) Investors
 b) Entrepreneurs
 c) Banks
 d) All of these

Answer the following Questions in detail :

- Q1. What is Environment Scanning? Discuss the importance of scanning of business environment.
 Q2. Explain Trend spotting. Discuss the different ways of trend spotting.
 Q3. Explain Creative Process.
 Q4. Explain the different forms of managing business organization in the private sector.
 Q5. Explain Production plan and its components.

Answer the following Case studies:

- Q.1 Ankit is into the business of manufacturing low-cost diesel-cars in Germany. He is earning good profits and ambitiously considering overseas expansion. He scans the environment for finding out the opportunities and threats that may influence his current and future plans. He zeroes down on India as a potential place for his business expansion as Indian Government has announced favorable trade regulations. On selling the first lot of cars in India. The Indian government noticed that the emissions from these cars were above the permissible limit. The government asked him to make necessary modification in his cars if he wanted to continue business in India. He readily agreed to meet the emission norms set by the Indian Government.
- (i) Quoting the lines from the above paragraph identify and explain any two environmental factors.
 (ii) Also, state any two values which Ankit tried to communicate to the Indian society.
- Q.2 Rajeev has just completed his B.Tech and wants to start his own business. He knew that the demand of electricity in India was increasing day by day, whereas its generation was not sufficient. Rajeev shared his views with some of his friends and they all decided to start the business of electricity generation. They experimented various methods and ultimately succeeded in electricity generation through garbage. They all were very happy as India is also facing the problem of garbage disposal.
- (i) Identify and explain the source of 'Idea-field' from where the idea has been generated by Rajeev and his friends.
 (ii) Also explain two other sources of idea-fields with the help of example.
- Q.3 Kapish an unemployed graduate got training for automobile repairing and allied services under PMKVY (Pradhan Mantri Kaushal Vikas Yojana) for skill development. He is planning to start a digital workshop for which he needs Rs. 25 Lakh. Though through MUDRA (Micro Units Development and Refinance Agency) he is able to get a loan of Rs. 10 Lakh but still he is falling short of Rs. 15 Lakh. He wants to pitch in his idea to potential investors through his business plan. Explain the different formats in which he can present his business plan for his start-up.

Q.4 Gunjan has just passed her senior secondary examination from a CBSE affiliated school. She wanted to start her own business but was unable to decide about the nature of the business. One day during the morning walk, her grandfather fell down in the park and was injured. She observed that her grandfather often forgets to take his medicines. Sh thought that the same problem may be faced by other old people. She thought to develop an instrument for old people that could be fitted with an electronic device connected to the mobile phones of the members of their family which could indicate the location of the old people when they go outside their homes. This device could be kept in their pockets. She also thought to fit a timer in the instrument that could remind the old persons about the time of taking their medicines. Identify and state the meaning of the concept described in the above para that helped Gunjan in structuring her idea for solving the problem.

Q.5 Gopal is a young man of 23 years. He has completed a tailoring course from an industrial training institute. He wants to start a big size tailoring shop in a posh colony where young men and women working in various multinational companies live. He went to one of his friend who had completed B.Tech course in textile designing to discuss about the opening of the tailoring shop. His friend advised him to prepare a written document describing formally all the relevant external and internal elements involving in starting a new venture. It will not only help in understanding the feasibility ad viability of the proposed venture but also dacilitate in assessing and making provisions for the bottlenecks in the progress and implementation of the idea. State any six points of importance of the concept discussed by Gopal with his friend.

-----X-----

SUBJECT – MASS MEDIA

- A. Design a 5-page newspaper titled DPS Times, Gwalior. Include a front page, school news, and Page 3 with editorial, op-editorial, sports news, current news, and Class X & XII Wall of Fame results. Add a creative corner and back page. Ensure neat layout, headings, and originality. Prepare
- B. Prepare a portfolio file separate for the entire year.
Do **TEN** Portfolio Questions for Holiday Homework.
- C. Revise all the chapters done.

-----X-----

SUBJECT – SANSKRIT

ग्रीष्मावकाश गृहकार्य

1. भू , कृ, लभ्, दृश् धातुओं के रूप लट्, लृट्, लङ्, लोट्, विधिलिङ् लकारों में लिखें। (नोट बुक में)
2. किम् शब्द के रूप पुल्लिंग, स्त्रीलिंग में तथा पितृ, गुरु, भवत्, नदी के रूप लिखें। (नोट बुक में)
3. 'भगवद् गीता' आधारित कोई सात श्लोक अर्थ सहित लिखें एवं कंठस्थ करें। (प्रयोजना कार्य फाइल में)

-----X-----

SUBJECT – PHYSICAL EDUCATION

1. SAI Khelo India Fitness Test

Purpose, Objective, Equipment/Infrastructure required, Test Administration and Scoring of following test items:

- (a) 50 M Sprint
- (b) 600 M Run/Walk

- (c) Push-ups
- (d) Partial Curl-ups
- (e) Sit & Reach Test

2. Procedure, Benefits and Contraindications of any two asanas for each lifestyle disease.

- (a) Obesity
- (b) Diabetes
- (c) Asthma
- (d) Hypertension
- (e) Back Pain & Arthritis

Paste Pictures also of asanas.

3. Anyone IOA recognized Sport/Game

- (a) Draw Labelled diagram of Field & Equipment and show all the specifications.
- (b) Rules, Terminologies & Skills.

Note: Students have to write these three Practicals in Practical Lab Manual.

-----X-----

SUBJECT – COMPUTER SCIENCE

List of Programs for Computer Sc.

1. Write a Program to show whether entered numbers are prime or not in the given range.
2. Input a string and determine whether it is a palindrome or not.
3. Find the largest/smallest number in a list/tuple
4. WAP to input any two tuples and swap their values.
5. WAP to store students' details like admission number, roll number, name and percentage in a dictionary and display information on the basis of admission number.
6. Write a program with a user-defined function with string as a parameter which replaces all vowels in the string with '*'.
7. Recursively find the factorial of a natural number.
8. Write a recursive code to find the sum of all elements of a list.
9. Write a recursive code to compute the nth Fibonacci number.
10. Read a text file line by line and display each word separated by a #.
11. Read a text file and display the number of vowels/ consonants/ uppercase/ lowercase and other than character and digit in the file.
12. Write a program that accepts a filename of a text file and reports the file's longest line.
13. Remove all the lines that contain the character `a' in a file and write it to another file.
14. Write a program to perform read and write operation onto a student.csv file having fields as roll number, name, stream and percentage.
15. Write a random number generator that generates random numbers between 1 and 6 (simulates a dice).

-----X-----

SUBJECT – HINDUSTANI VOCAL MUSIC

1. Learn the definition of the following and Do practical exercises as well : Alankar , kan , meend , khatka , murki , gamak
2. Brief study about Historical development of time theory of ragas.

-----X-----

SUBJECT – PAINTING

Practical I - Compose a scene of market or festival with two front face figures on buff sheet.

Size : Half Imperial

Medium: Poster or water color

Practical 2 - Compose a still life.

Objects Required: A bottle-gourd (note less than 25 cm in length) half a papaya, two tomatoes, a big size onion and a capsicum. Arrangement: Place the bottle-gourd on the table leaning against the backdrop. Place the papaya, tomatoes, onion and capsicum in front of it. The inside part of the papaya should be visible. The whole arrangement should be kept well below the eye level.

Visit

Size : Half imperial

Medium: Poster or water color

-----x-----

SUBJECT – DANCE

Write definitions and do practical exercise as well

Thaat , aamad , gat nikaas , gat bhaav

-----x-----